

PLEASE READ this sheet prior to assembly to familiarise yourself with the various stages of construction. Carefully open the pack supplied and check the contents against the parts and fittings check list.

Do not destroy any of the packaging until you are certain that you have all the necessary parts for the assembly.

Please ensure that the packaging is disposed of in a safe environmentally friendly way.

CAUTION: There are small components used in the construction of this unit. These loose items should be kept away from young children during assembly, to avoid the danger of choking.

IMPORTANT: BEFORE STARTING TO ASSEMBLE THE BED - PLEASE READ THESE INSTRUCTIONS CAREFULLY.

Parts Identification

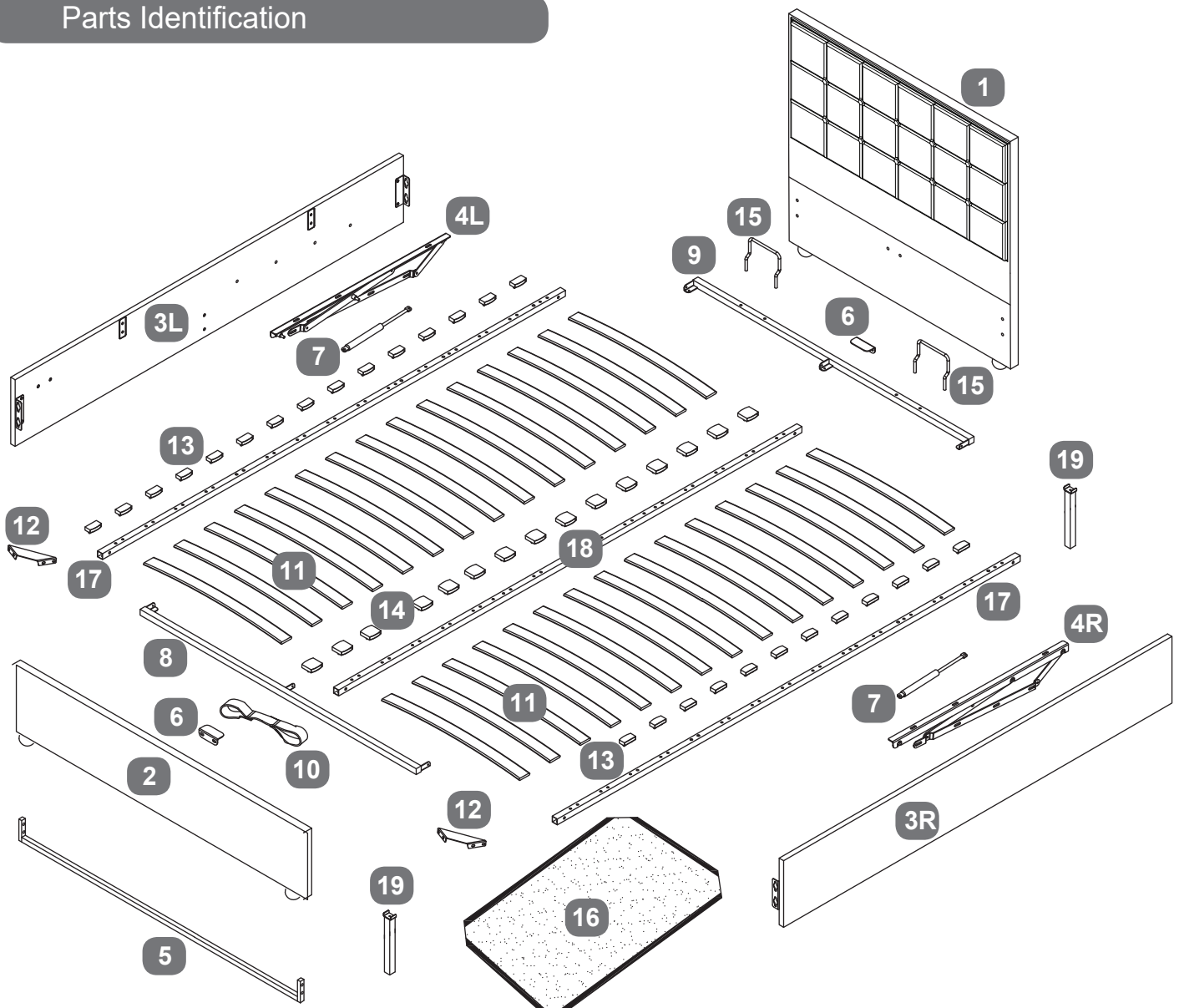









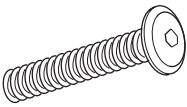

Parts Checklist

Ref.	Description	Qty	Ref.	Description	Qty
1	Headboard	1	11	Wooden Slat Double/King	28/30
2	Footboard	1	12	Angle Bracket	2
3L & 3R	Side Rail - LH & RH	1 Pr	13	Single Plastic Cap Double/King	28/30
4L & 4R	Lift Mechanism - LH & RH	1 Pr	14	Double Plastic Cap Double/King	14/15
5	'U' Shaped Bar	1	15	Mattress Stopper	2
6	Frame Support Bracket	2	16	Fabric Base Cover	1
7	Gas Lift Piston	2	17	Side Rail for Metal Slat Frame	2
8	Cross Bar for Metal Slat Frame - Footend	1	18	Centre Rail for Metal Slat Frame	1
9	Cross Bar for Metal Slat Frame - Headend	1	19	Centre Support Legs	2
10	Fabric Handle	1			

Fittings Checklist

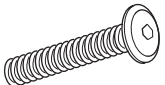
HARDWARE NEEDED FOR BED ASSEMBLY

Code	Description	Qty	Code	Description	Qty
A	Bolts (M8x45mm) for fitting Metal Slat Frame to Lift Mechanism (4) and fitting 'U' Shaped Bar (5) to Side Rails. 	x10	F	Loc-nuts for M8 Metal Slat Frame bolts and Gas Lift pistons 	x10
B	Bolts (M8x30mm) for fitting Lift Mechanism (4) to Side Rails 	x8	G	Flat Washers for M8 bolts 	x2
C	Bolts (M8x16mm) for fitting Frame Support Brackets (6) and Angle Brackets (12) to Headboard and Footboard (1&2) 	x12	H	Bolts (M8x25mm) for fitting Side Rails (3) to Headboard & Footboard (1&2) 	x8
D	Bolts (M6x10mm) for assembling Metal Slat Frame 	x12	J	Allen Key for M8 bolt 	x1
E	Bolts (M6x40mm) for fitting Centre Support Bar Legs (19) to Metal Slat Frame 	x2	K	Spanner for M8 nut 	x1

Additional Tools Required

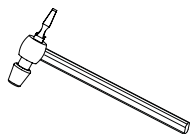

Care & Maintenance

In the unlikely event of missing or damaged parts, please contact your retailer. Please have this guide at hand quoting the part code reference numbers shown when requesting spare or replacement parts.

General Hints & Tips



Please retain your assembly instruction and tools provided for future use. Periodically check that all bolts are still tight.

Assembly requires two persons.



Approximate time to assemble this product

Bed Assembly

Stage
1

C  x4 J  x1

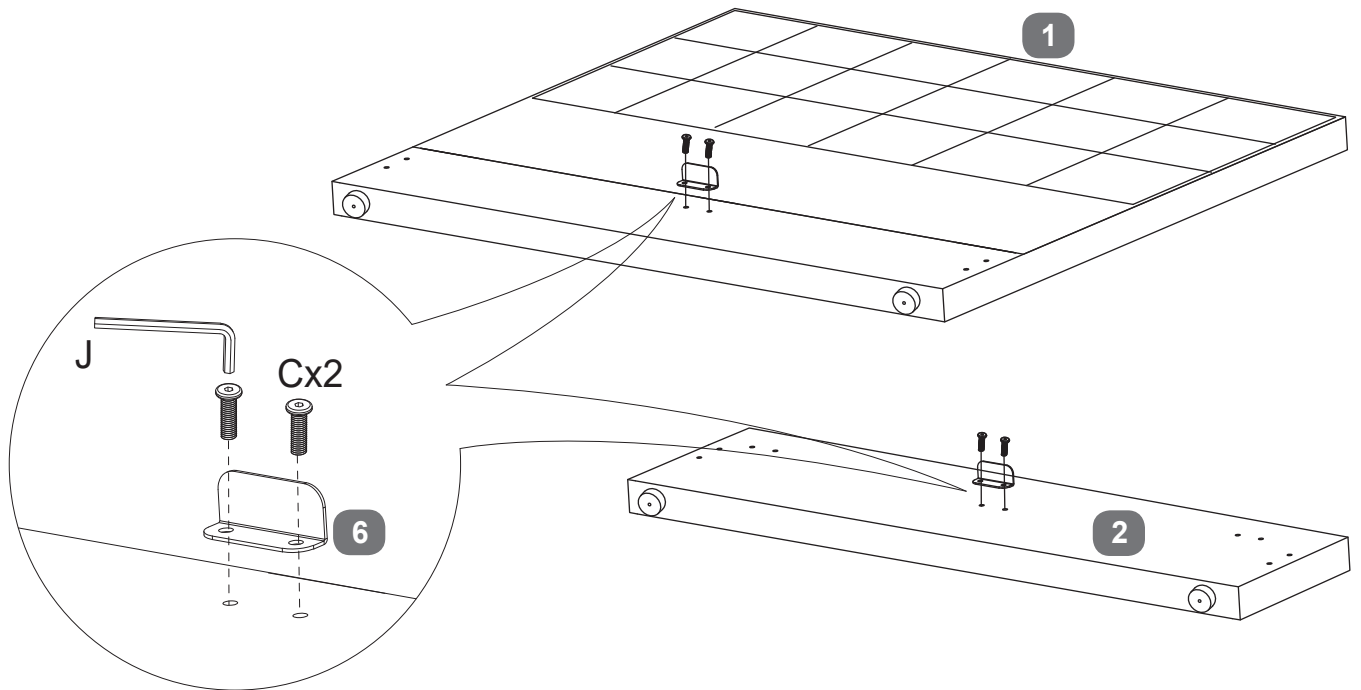

Stage
2

B  x8 J  x1

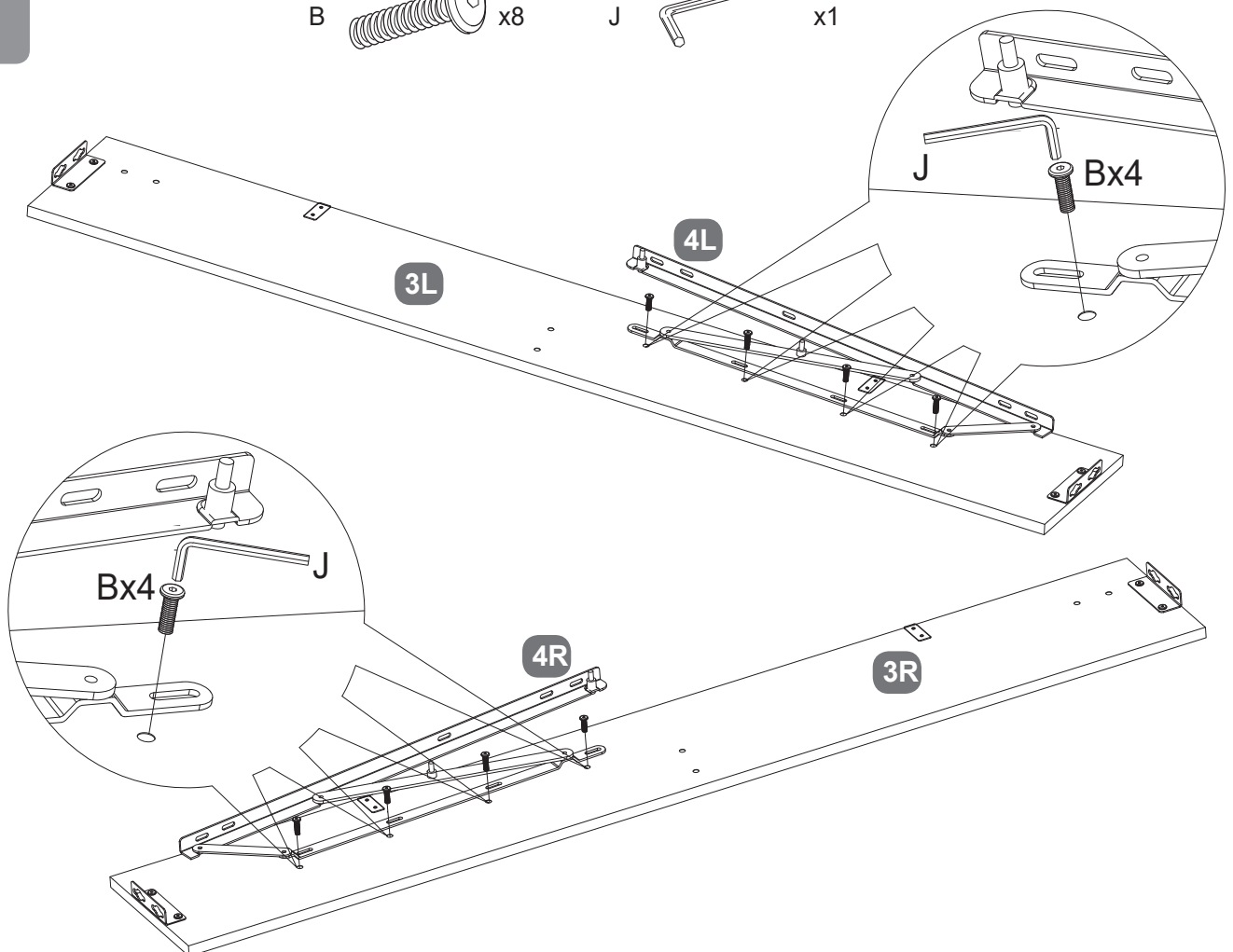

Bed Assembly

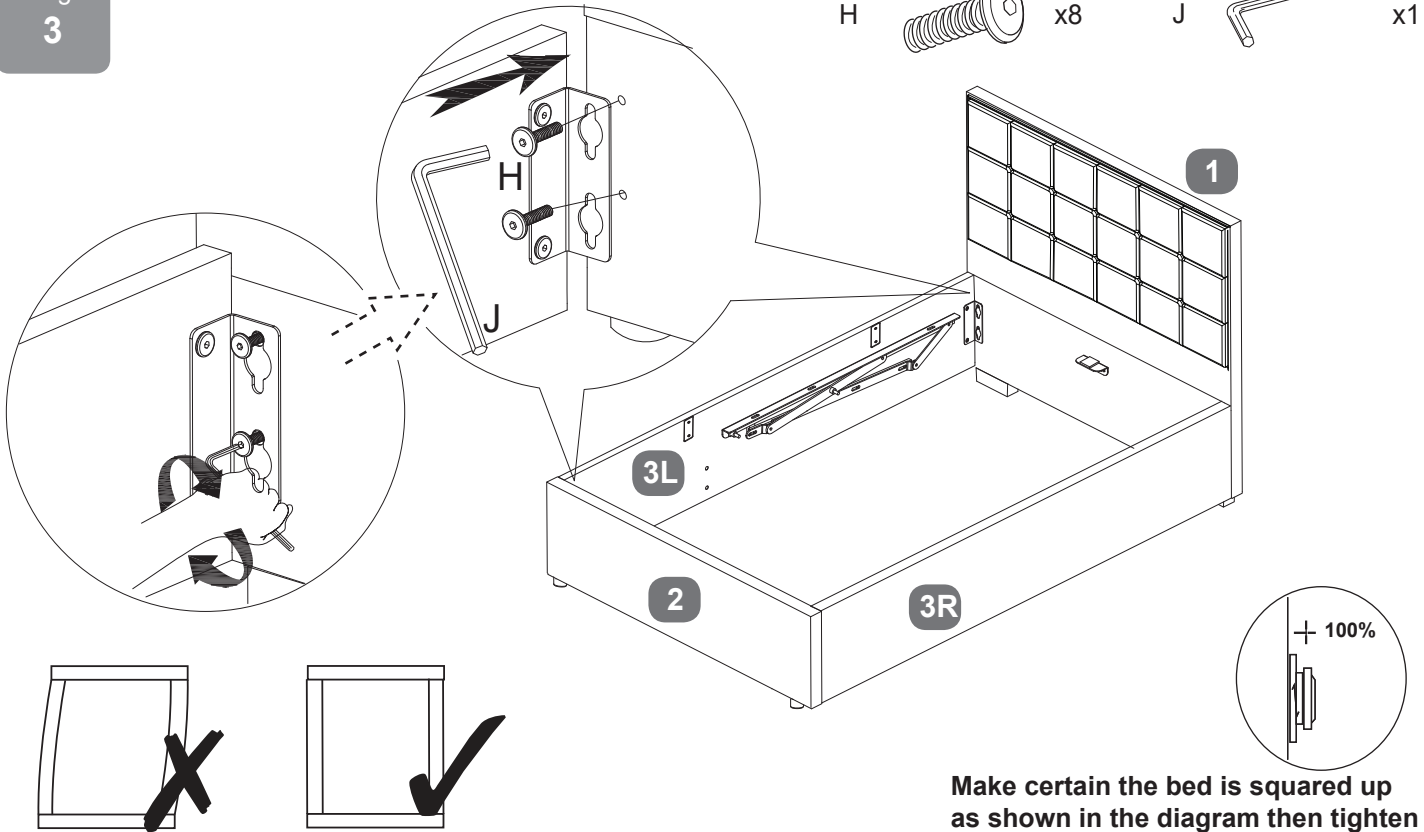

Stage
3

H  x8 J  x1

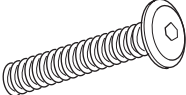

Make certain the bed is squared up as shown in the diagram then tighten all bed assembly bolts 100%.

Stage
4

A  x4 C  x8 J  x1

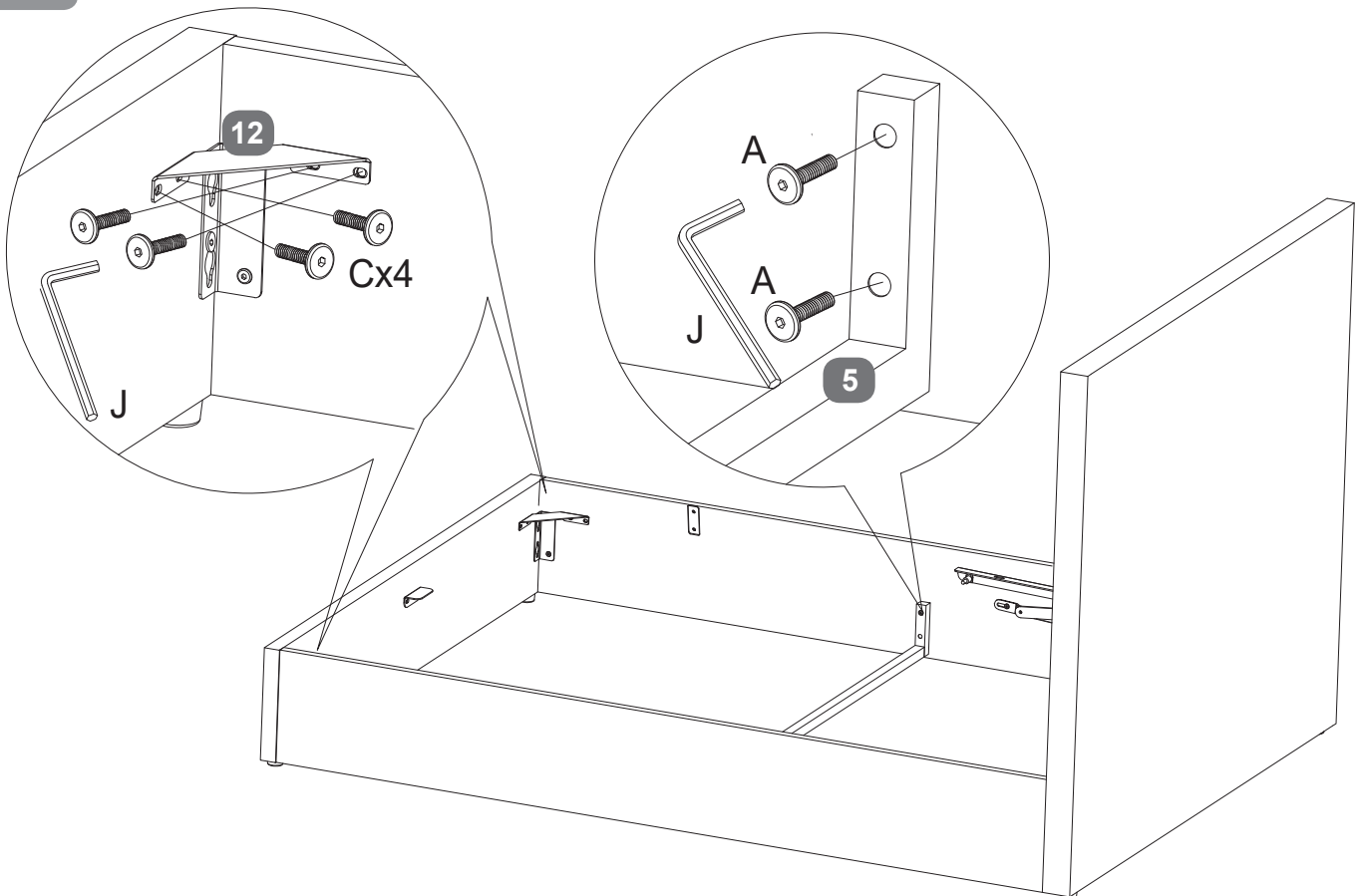

Bed Assembly

Stage
5

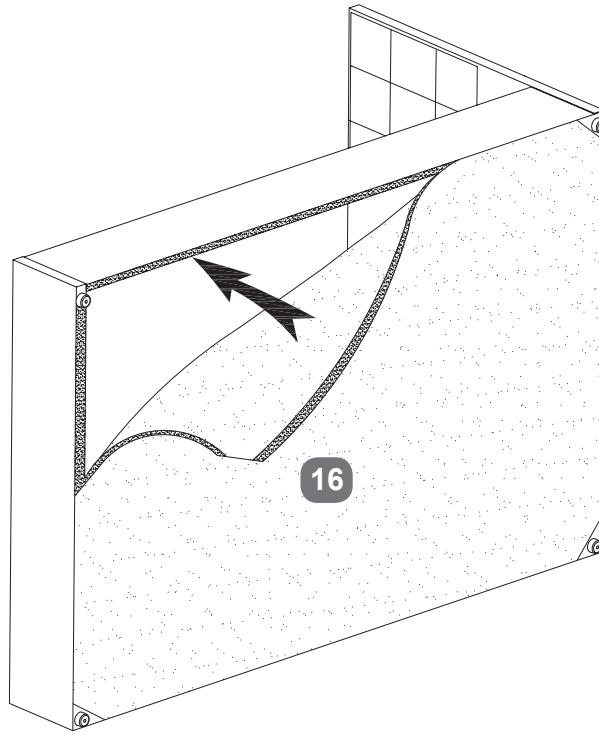

Stage
6

This is looking from underneath the Metal Slat Frame. Please ensure that the holes for Gas Lift Mechanisms are aligned as shown

D  x12 J  x1

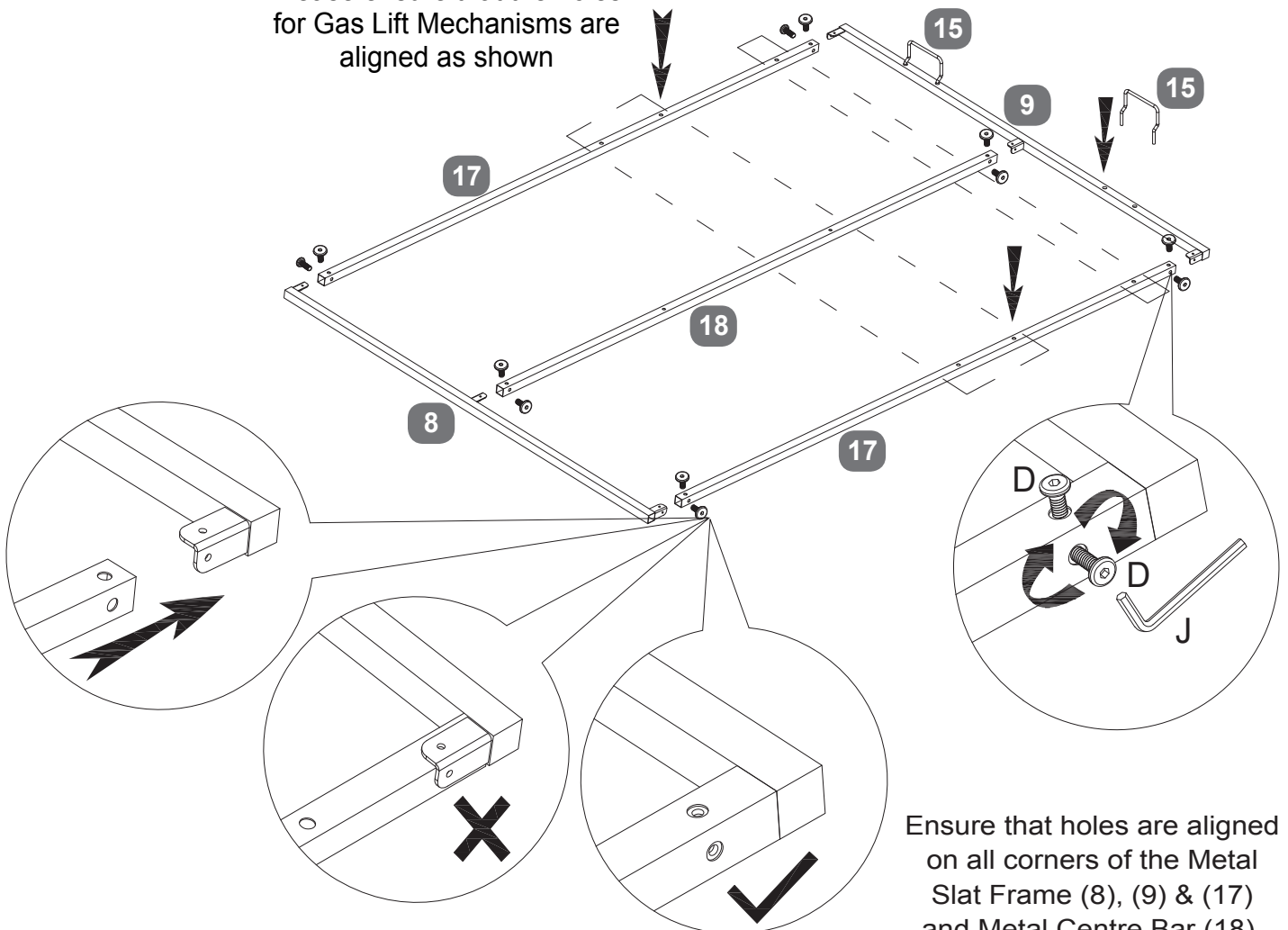





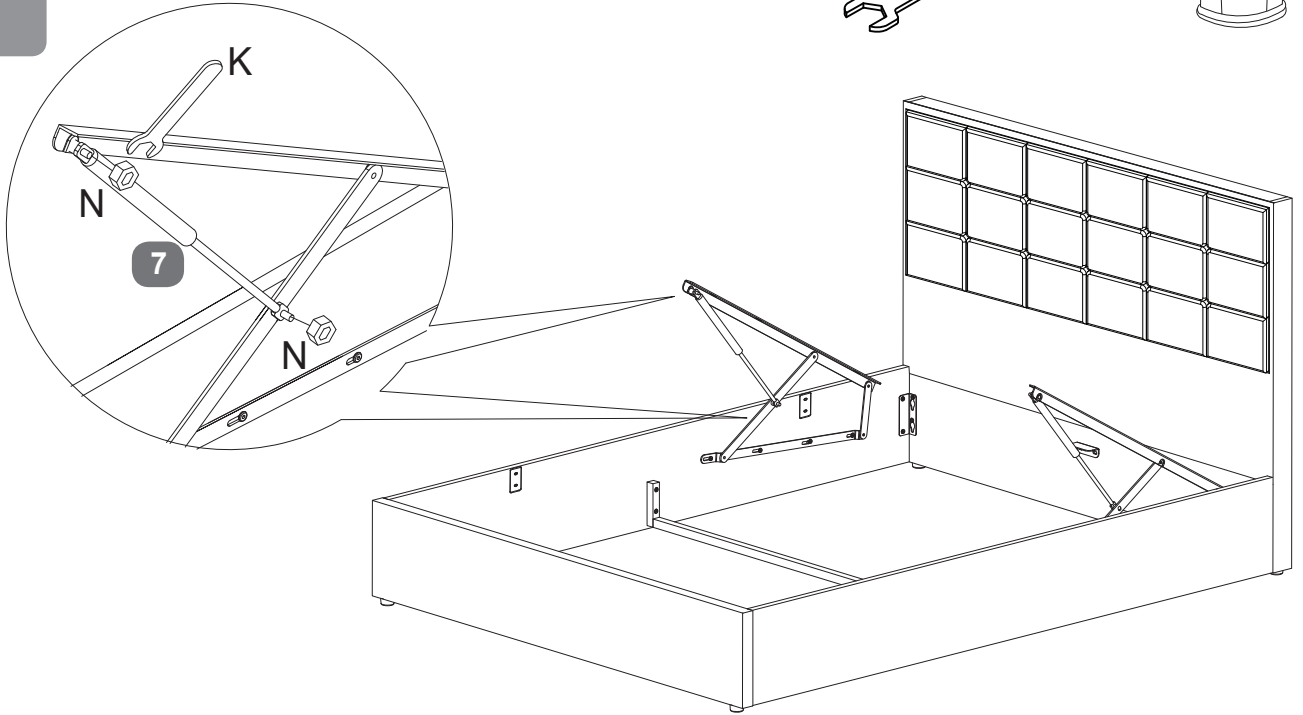

Bed Assembly

Stage
7

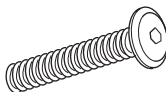
K  x1 N  x4



Stage
8

A  x6 E  x2 F  x6
G  x2
J  x1
K  x1

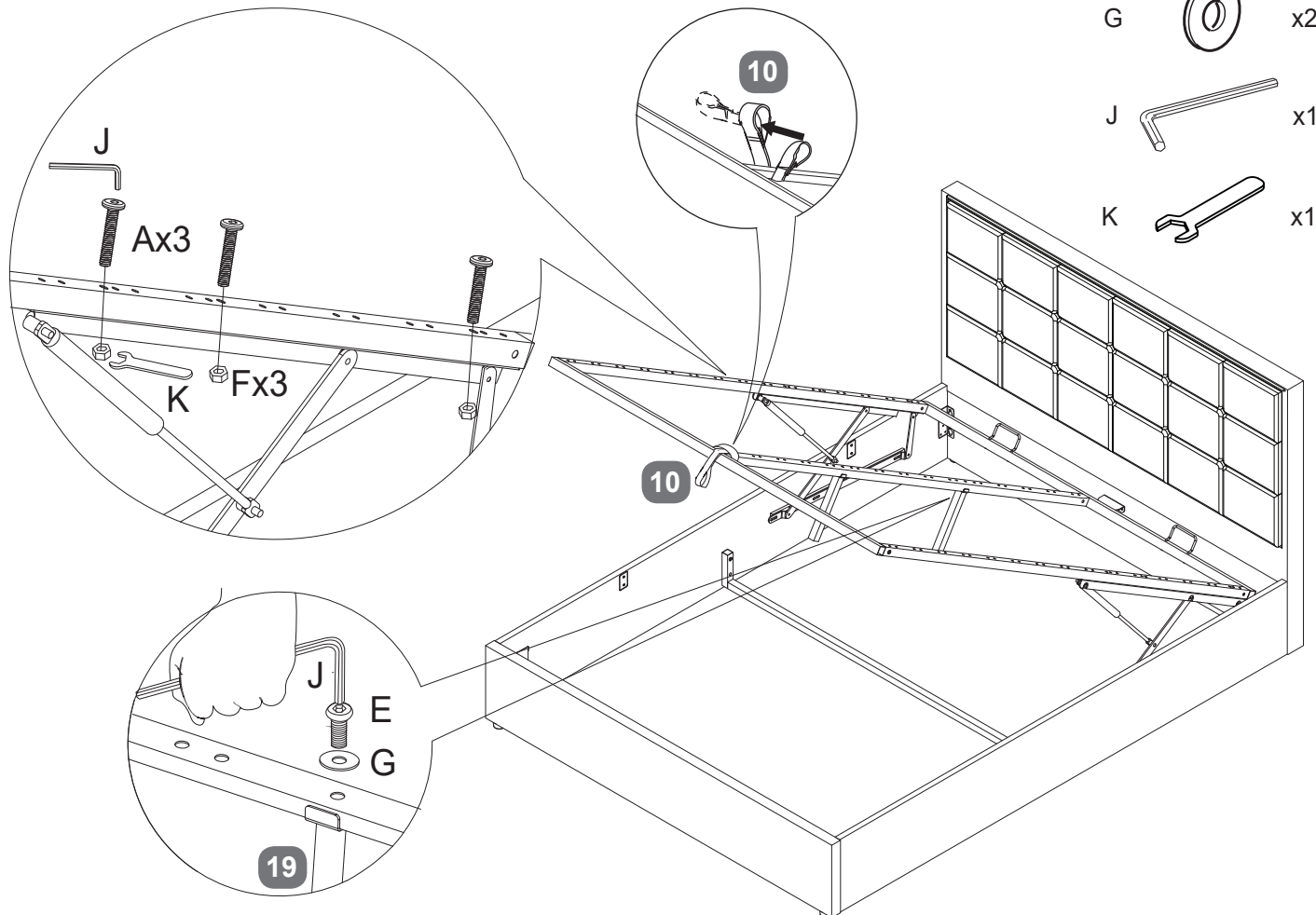

Bed Assembly

Stage
9

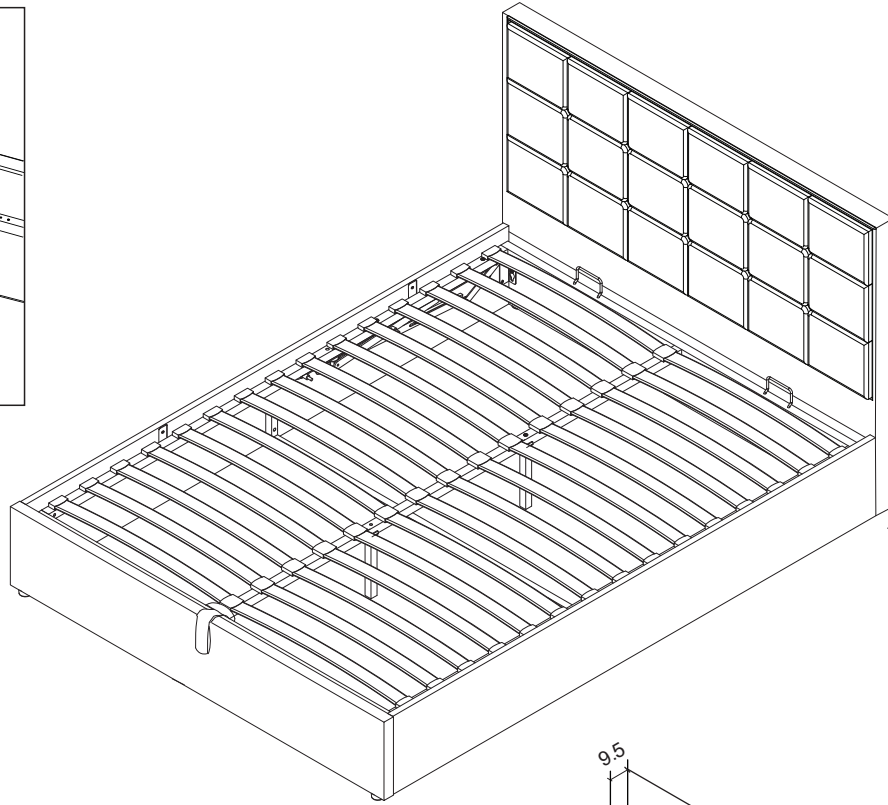
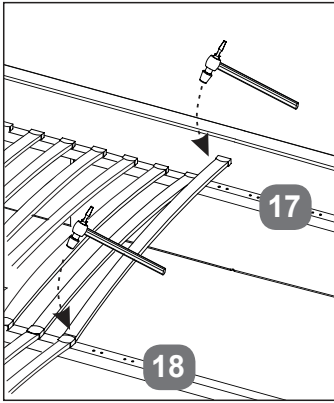
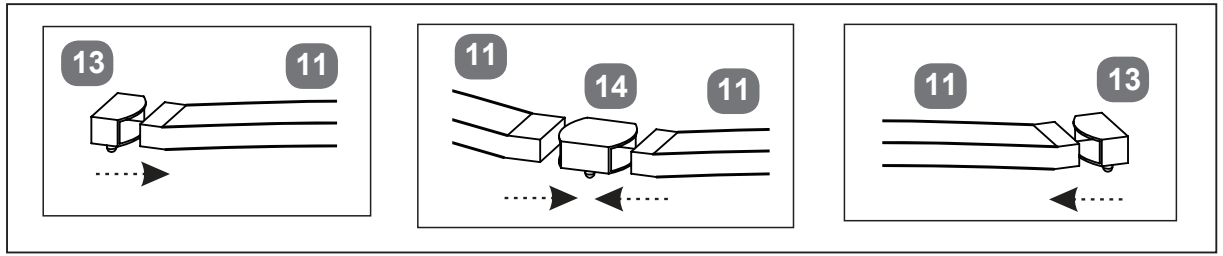

Overall Dimension (L x W x H CM)

Double: 205.5 x 144 x 136/31

King : 215.5 x 159 x 136/31

Storage Dimension (L x W x H CM)

Double: 193 x 137.5 x 22.5

King : 203 x 152.5 x 22.5

